

BMW - ñõàìù Mitchell On-Demand.

Äëÿ ïëó÷áíëÿ íóæíé ïðèíöèìèàèüíé ñõàìù âúááðèðá ãíä, ïíáäëü.

[Fig. 10: Rear Compartment & Accessories \(Cont.\)](#), 57810 byte

[Fig. 11: Rear Compartment & Accessories \(Cont.\)](#), 51261 byte

[Fig. 12: Power Window \(2-Door\)](#), 124898 byte

[Fig. 1: Engine Compartment](#), 52107 byte

[Fig. 2: Engine Compartment \(Cont.\)](#), 58820 byte

[Fig. 3: Fuse Block & Underdash](#), 42506 byte

[Fig. 4: Fuse Block & Underdash \(Cont.\)](#), 42318 byte

[Fig. 5: Underdash \(Cont.\)](#), 51521 byte

[Fig. 6: Underdash \(Cont.\) & Instrument Panel](#), 55180 byte

[Fig. 7: Underdash & Instrument Panel \(Cont.\)](#), 62049 byte

[Fig. 8: Instrument Panel \(Cont.\)](#), 55200 byte

[Fig. 9: Rear Compartment & Accessories](#), 46569 byte

Ìà ÿòèõ ñòðàìé÷èàõ ïðááñòàáèäíú ñõàìù èç Mitchell .

Âñá ïðààà ìà ääííúé ïðíäóèð ïðèìäèäèæèð [Mitchell International](#).

Èèöáíçèííúá äèñèè Mitchell âú ïæáðá ïðèìáðáñòè òíëüèí â [AmEuro International Inc](#)

(109387, Ìñéàà Êðáñííäàðñèàÿ 13, îðèñ À1 òàè. (095) 352-67-00 òàèñ. (095) 352-67-05).

Ìñòáðááèèðáñü ïíááäèè!

Ìú âúèèääúääàì ìèçáðíóð ÷áñòü ÿóíáí çàìá÷àðäèüíáí ñíðáâí÷èèà ñ òæëþ áâí ïíóéÿðèçàòèè â Ðíññèè.

Ìàøà ðááíðà çàèèð÷àèáñü òíëüèí â ïðáíðàçíááèè â òíðìàð PDF.

Diakom-Auto: 22, Chehova, Taganrog, Rostov-Don reg., Russia, Tel: (8634) 315187

WIRING DIAGRAMS

Fig. 10: Rear Compartment & Accessories (Cont.)

1988 BMW 325i

For DIAKOM-AUTO <http://www.diakom.ru> Taganrog support@diakom.ru (8634)315187

Copyright © 1998 Mitchell Repair Information Company, LLC

Friday, November 03, 2000 04:46PM

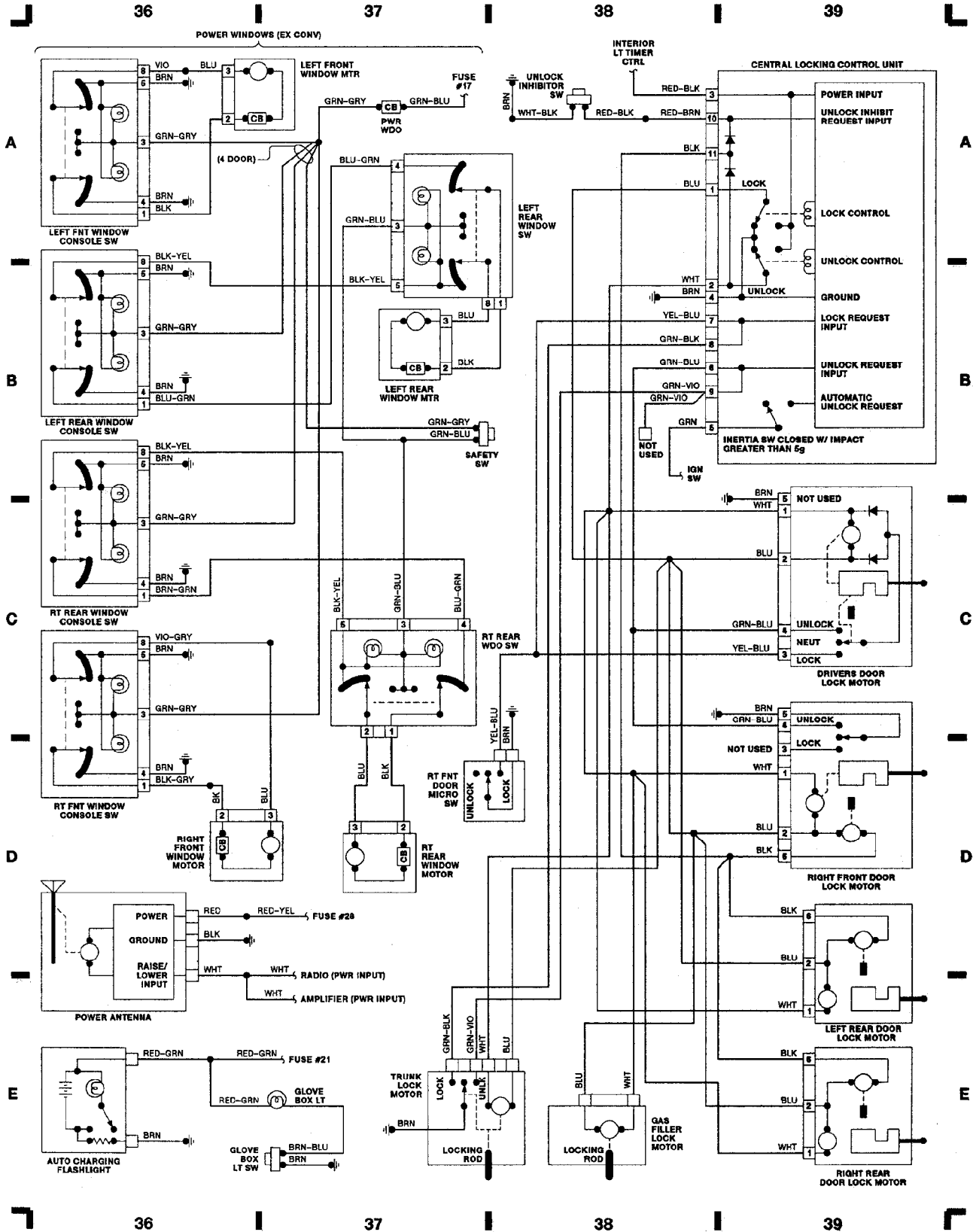

WIRING DIAGRAMS

Fig. 11: Rear Compartment & Accessories (Cont.)

1988 BMW 325i

For DIAKOM-AUTO <http://www.diakom.ru> Taganrog support@diakom.ru (8634)315187

Copyright © 1998 Mitchell Repair Information Company, LLC

Friday, November 03, 2000 04:46PM

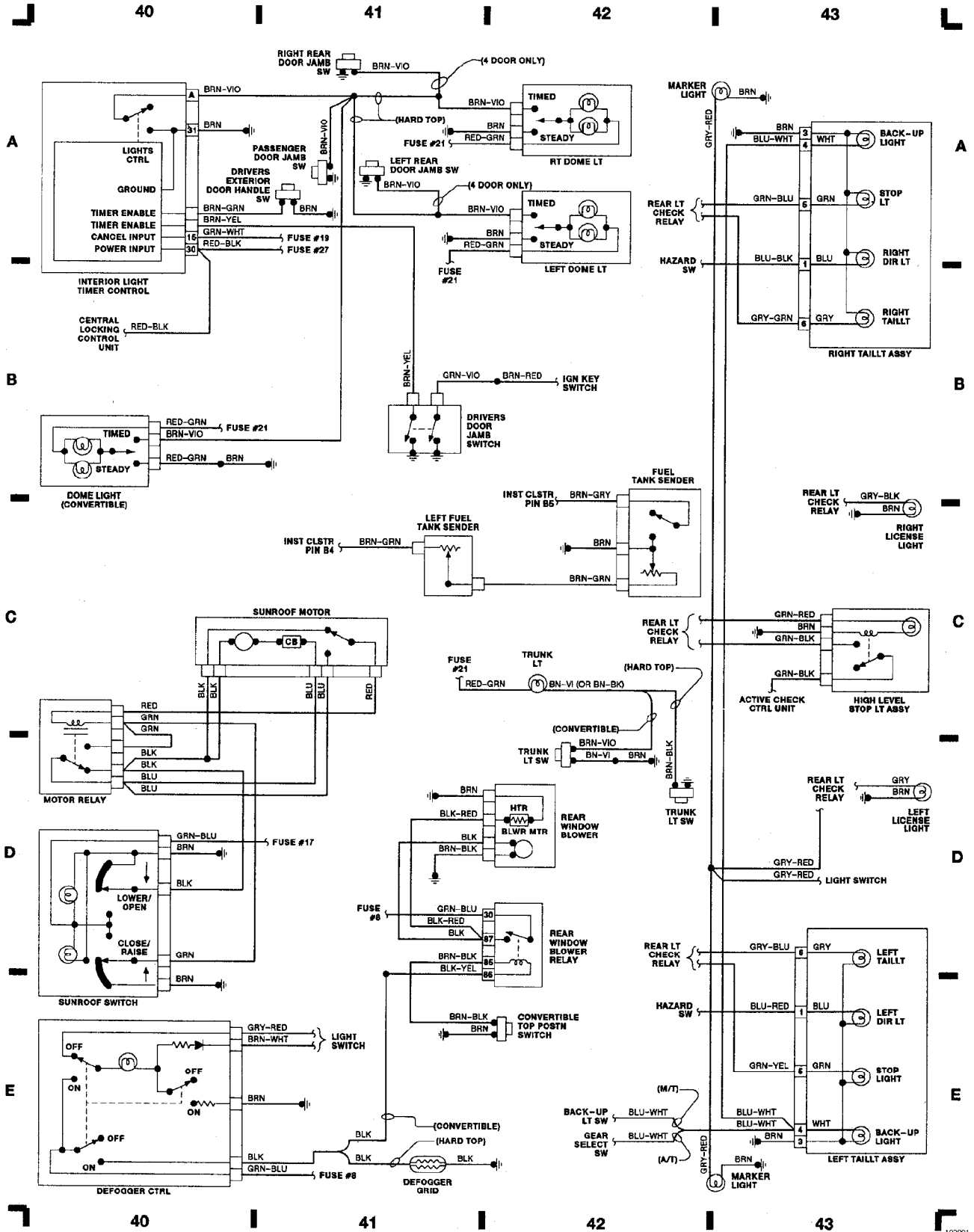

WIRING DIAGRAMS

Fig. 12: Power Window (2-Door)

1988 BMW 325i

For DIAKOM-AUTO <http://www.diakom.ru> Taganrog support@diakom.ru (8634)315187
 Copyright © 1998 Mitchell Repair Information Company, LLC
 Friday, November 03, 2000 04:46PM

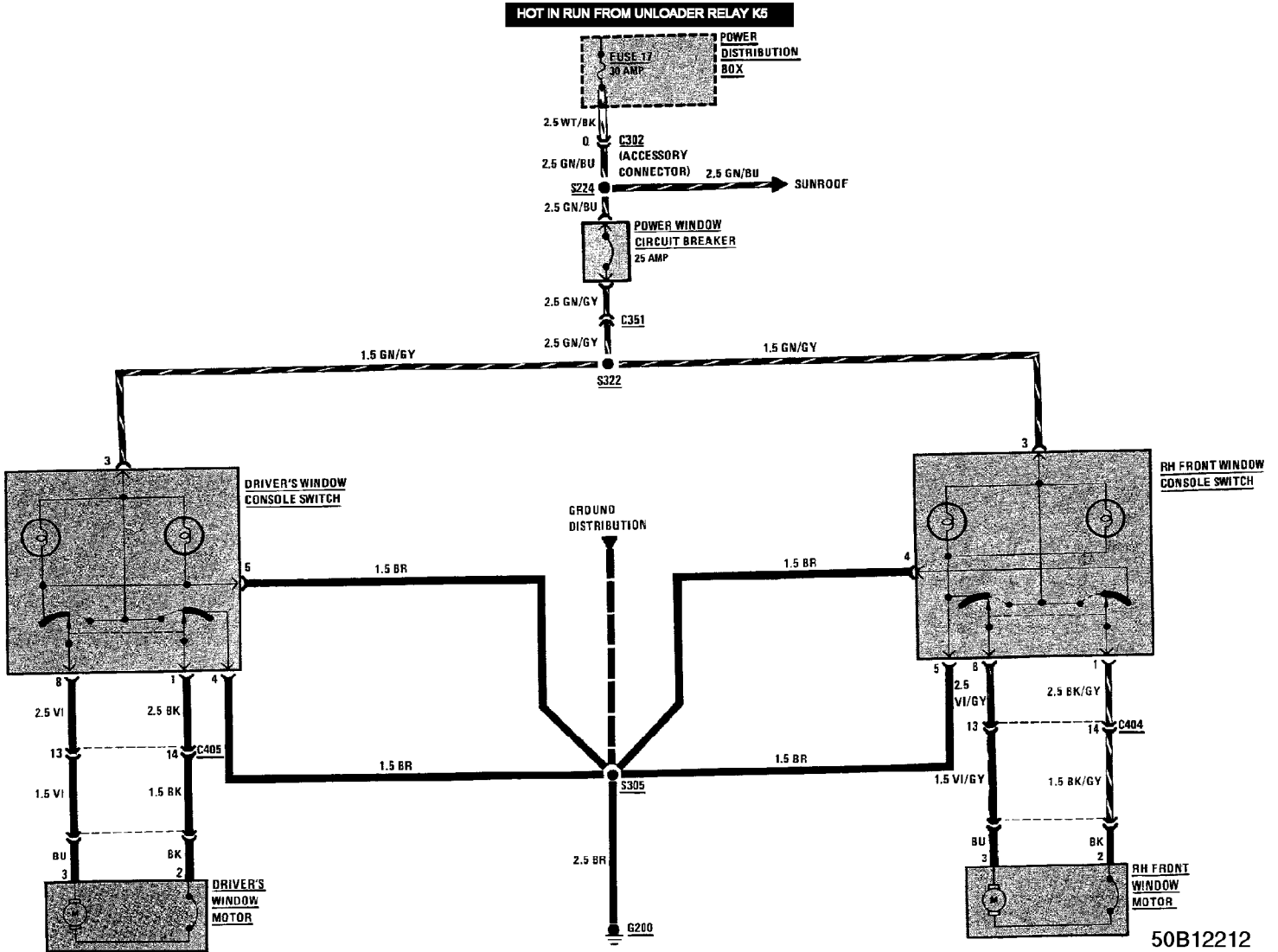

50B12212

WIRING DIAGRAMS

Fig. 1: Engine Compartment

1988 BMW 325i

For DIAKOM-AUTO <http://www.diakom.ru> Taganrog support@diakom.ru (8634)315187
 Copyright © 1998 Mitchell Repair Information Company, LLC
 Friday, November 03, 2000 04:38PM

COMPONENT LOCATOR:

A/C CONTROL SWS	C 16
ABS CONTROL UNIT	A-B 20
ACTIVE CHECK CONTROL UNIT	E 20-23
ALTERNATOR	B-C 3
AUTO CHARGE FLASHLT	F 36
AUX FAN BLOWER RESISTOR	C 12
AUX FUSE BLOCK	D 12
BACK-UP LT SW	D 36
BATTERY	A 2
BATTERY J/B	A 2
BRAKE FLUID LEVEL SW	C 31
BRAKE SW	D 20
CENTRAL LOCK CTRL UNIT	A-B 39
CHIME MODULE	C 19
CIG LIGHTER	D 32
CLUTCH SW	C 26
COMBINATION SW	C 24
COMPUTER HORN	E 17
COMPUTER MODULE	E 19
CRUISE CTRL SW	E 27
CRUISE CTRL UNIT	D 27
DEFOG CTRL	F 40
DIAG CONN	E 5-6
DOME LT (CONVERTIBLE)	B 40
DRIVERS DOOR JAMB SW	B 41
DUAL TEMP SW	C 15
FOG LT SW	C 24
FUEL PUMP	A 7
FUEL PUMP RLY	B 7
FUSE BLOCK (PARTIAL)	B-D 8-11
FUSE BLOCK (PARTIAL)	A-B 12-15
GEAR SEL SW (A/T)	C 35
HAZARD SW	D-E 24
HIGH LEVEL STOP LT ASSY	C 43
HORN SWS	D 33
IGNITION COIL	A 4
IGNITION KEY-IN SW	C 18
IGNITION SW	E 12-15
INSTRUMENT CLUSTER	A 26
INTERIOR LT TIME CTRL	A 40
K10 WIPER CTRL UNIT	E 32
LEFT FUEL TANK SENDER	C 41
LEFT/RIGHT DOME LTS	A 42
LIGHT SW	A-B 24
MAIN RLY	D 7
MAP READING LT	C 20
MIRROR CTRL SW	C 32
MULTI-FUNCTION CLOCK	D 16
ON BOARD COMPUTER RLY BOX	D 17
OVERVOLTAGE PROTECT RLY	C 23
OXYGEN SENSOR	B 7
POWER ANTENNA	D 36
POWER WINDOW CB (CONVERTIBLE)	B 33
POWER WINDOW CB (W/O CONV)	A 37
REAR LTS CHECK RLY	A 27
REAR WINDOW BLOWER RLY	D 42
SEAT BELT WARN TIMER	E 17
STARTER MOTOR	B 3
STARTER RLY	E 3
SUNROOF SW	D 40
TRUNK LT SW	C 42
WASHER PUMP	E 33

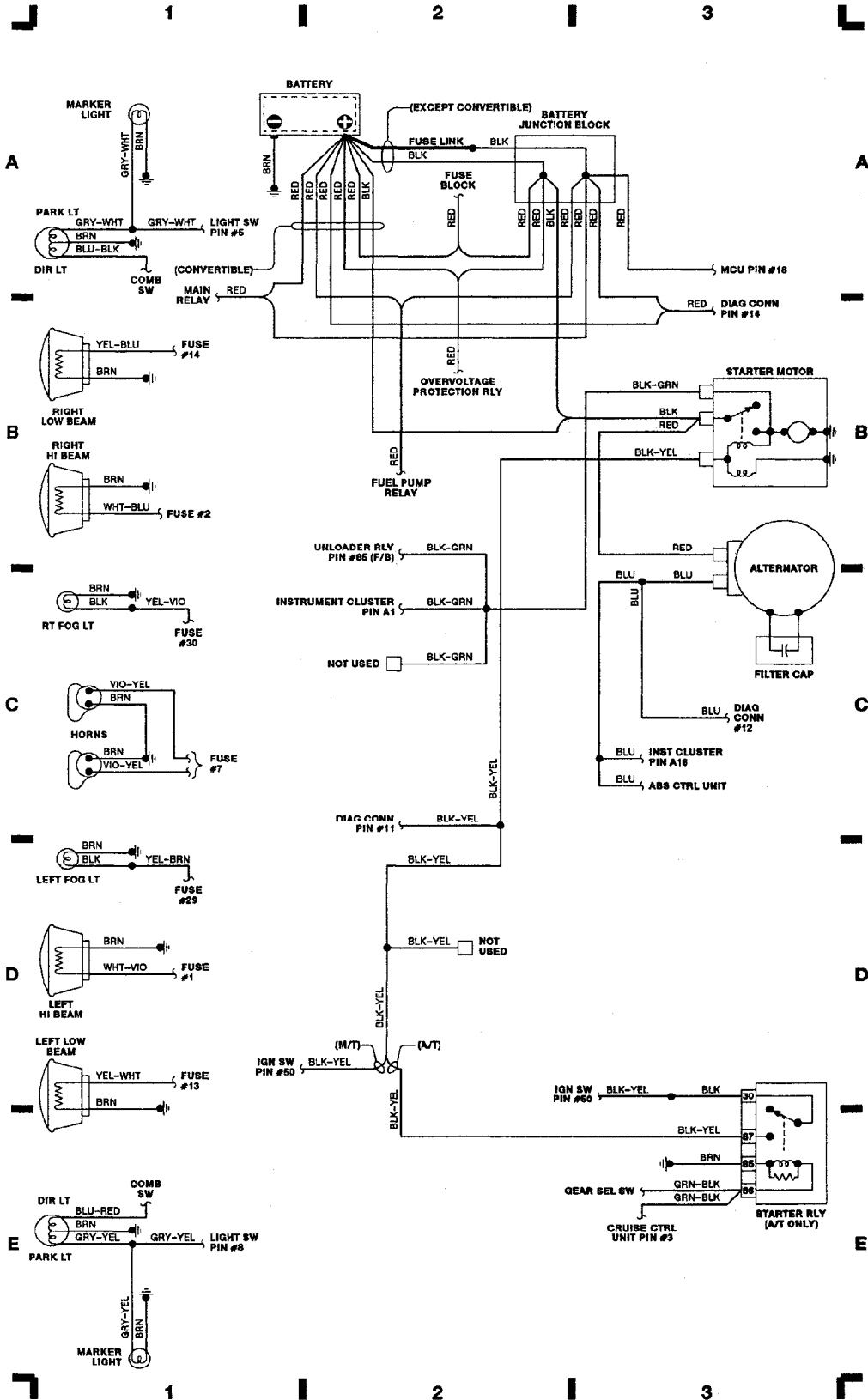

WIRING DIAGRAMS

Fig. 2: Engine Compartment (Cont.)

1988 BMW 325i

For DIAKOM-AUTO <http://www.diakom.ru> Taganrog support@diakom.ru (8634)315187
 Copyright © 1998 Mitchell Repair Information Company, LLC
 Friday, November 03, 2000 04:38PM

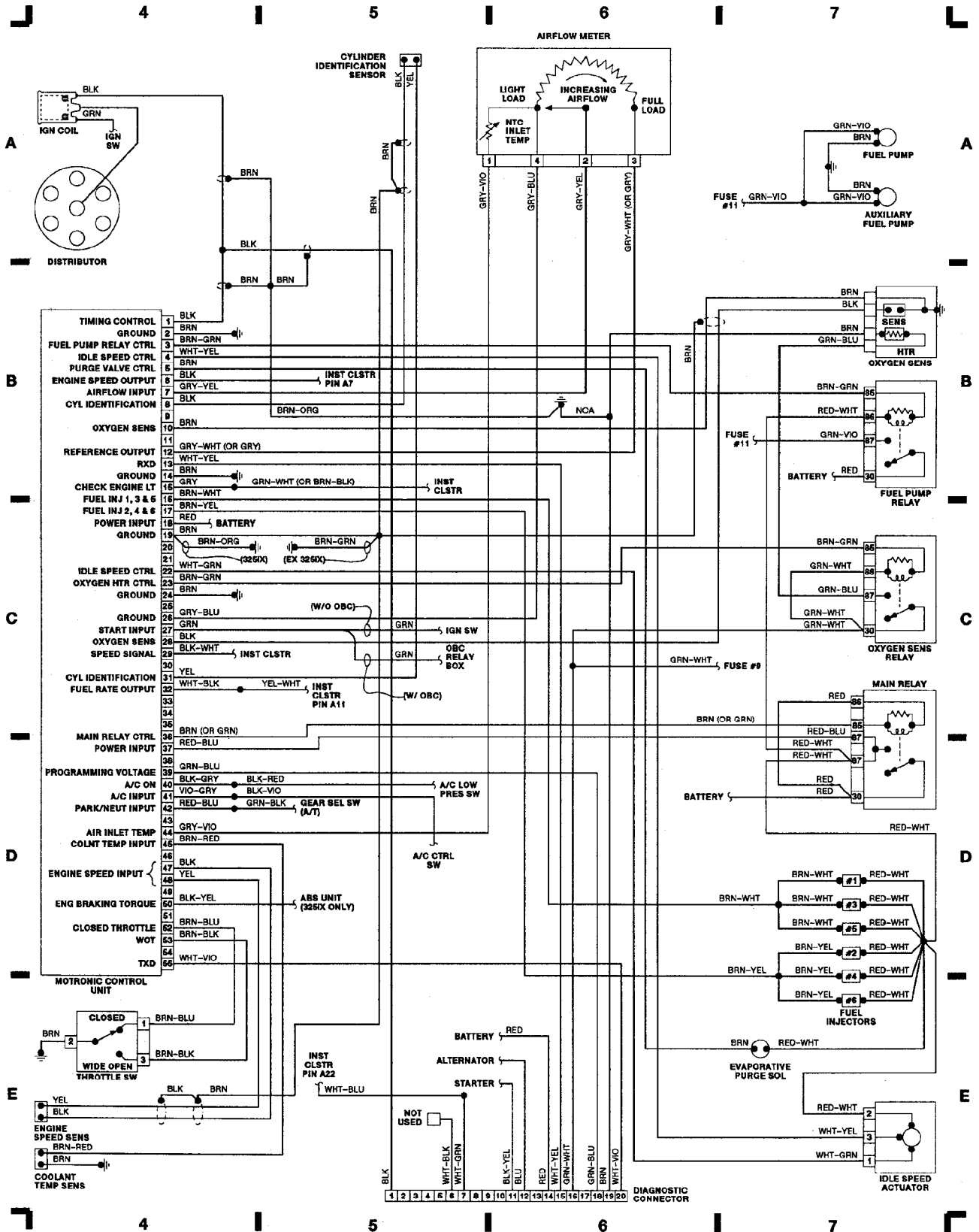

WIRING DIAGRAMS

Fig. 3: Fuse Block & Underdash

1988 BMW 325i

For DIAKOM-AUTO <http://www.diakom.ru> Taganrog support@diakom.ru (8634)315187
 Copyright © 1998 Mitchell Repair Information Company, LLC
 Friday, November 03, 2000 04:38PM

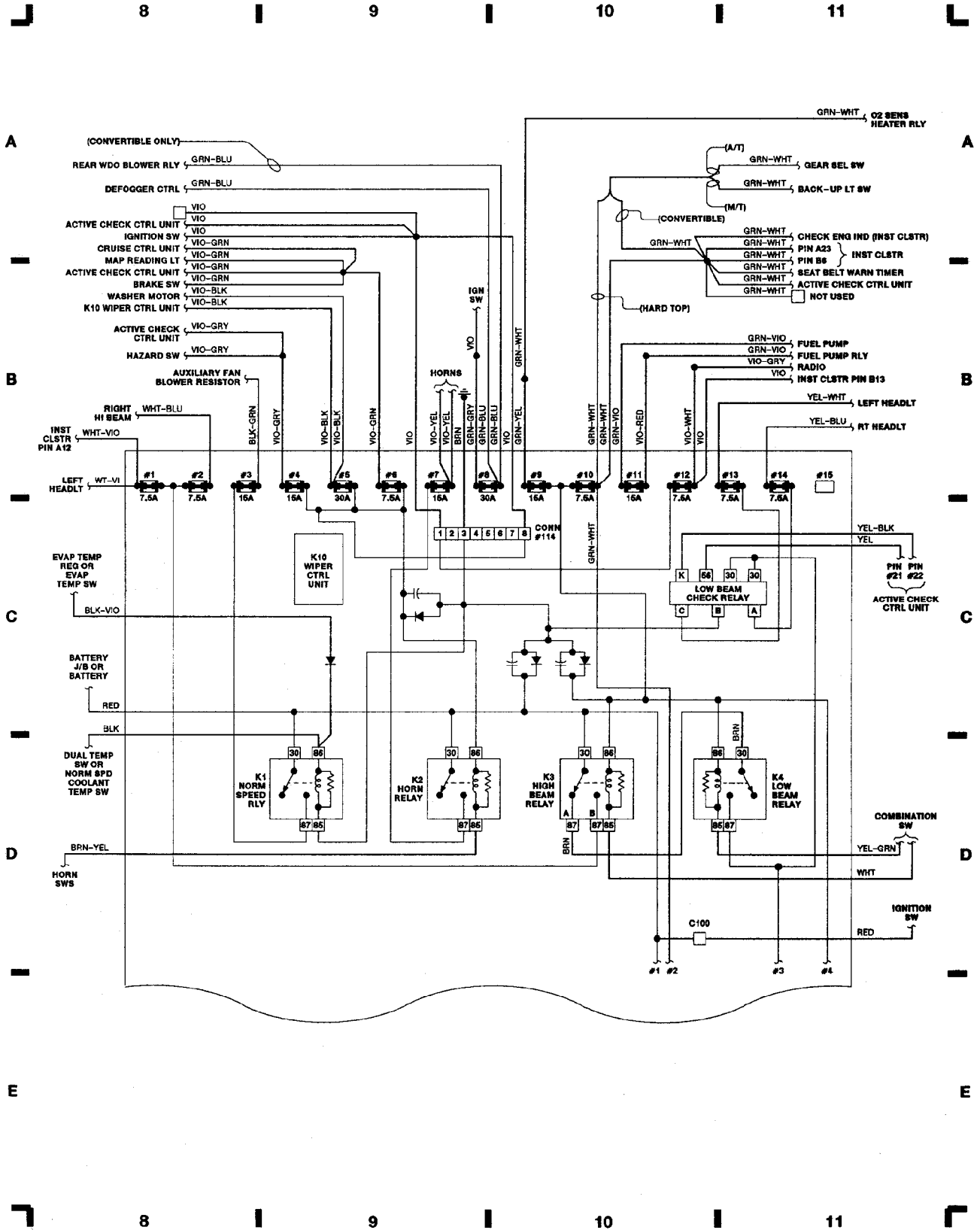

WIRING DIAGRAMS

Fig. 5: Underdash (Cont.)

1988 BMW 325i

For DIAKOM-AUTO <http://www.diakom.ru> Taganrog support@diakom.ru (8634)315187
 Copyright © 1998 Mitchell Repair Information Company, LLC
 Friday, November 03, 2000 04:38PM

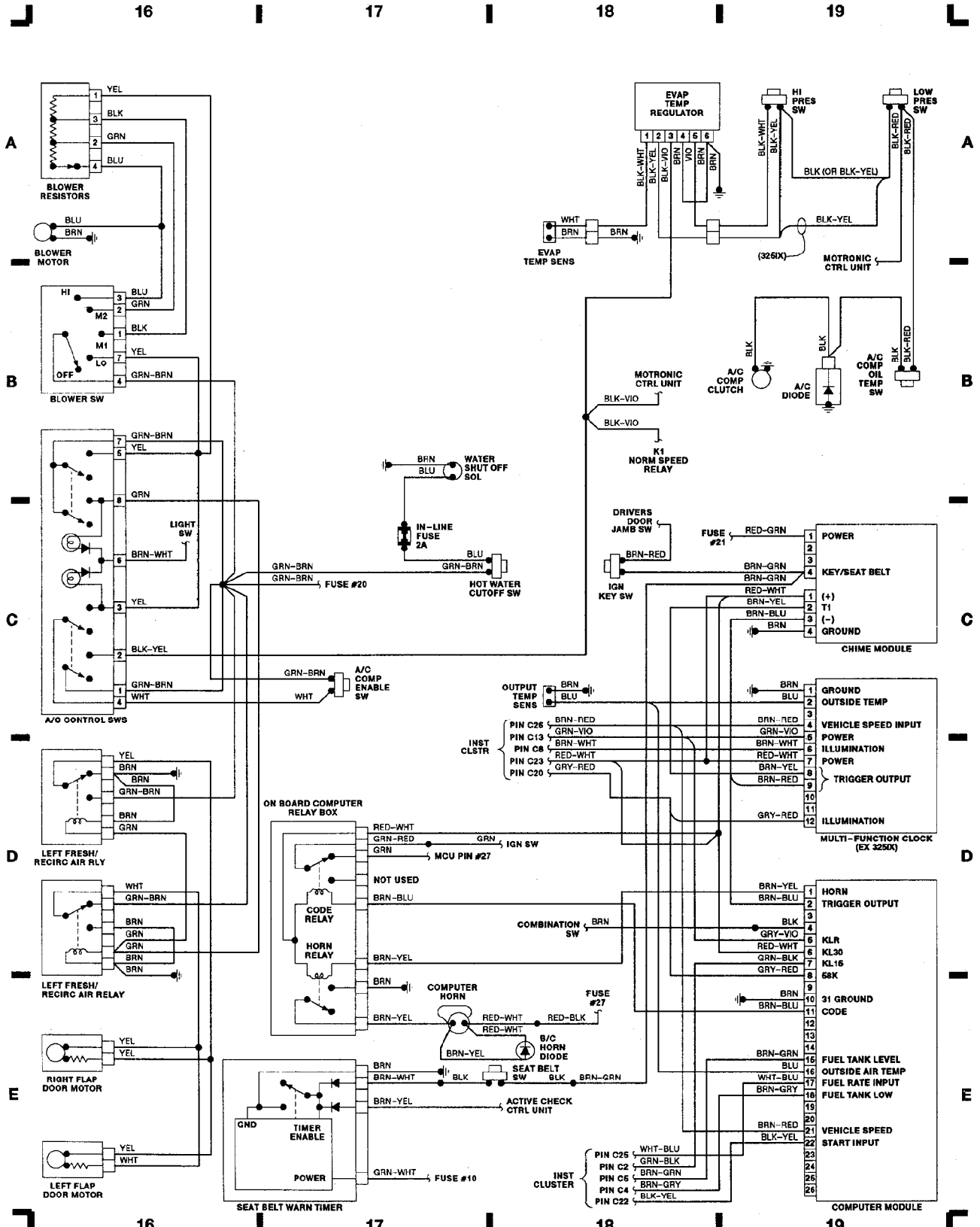

WIRING DIAGRAMS

Fig. 6: Underdash (Cont.) & Instrument Panel 1988 BMW 325i

For DIAKOM-AUTO <http://www.diakom.ru> Taganrog support@diakom.ru (8634)315187
Copyright © 1998 Mitchell Repair Information Company, LLC
Friday, November 03, 2000 04:38PM

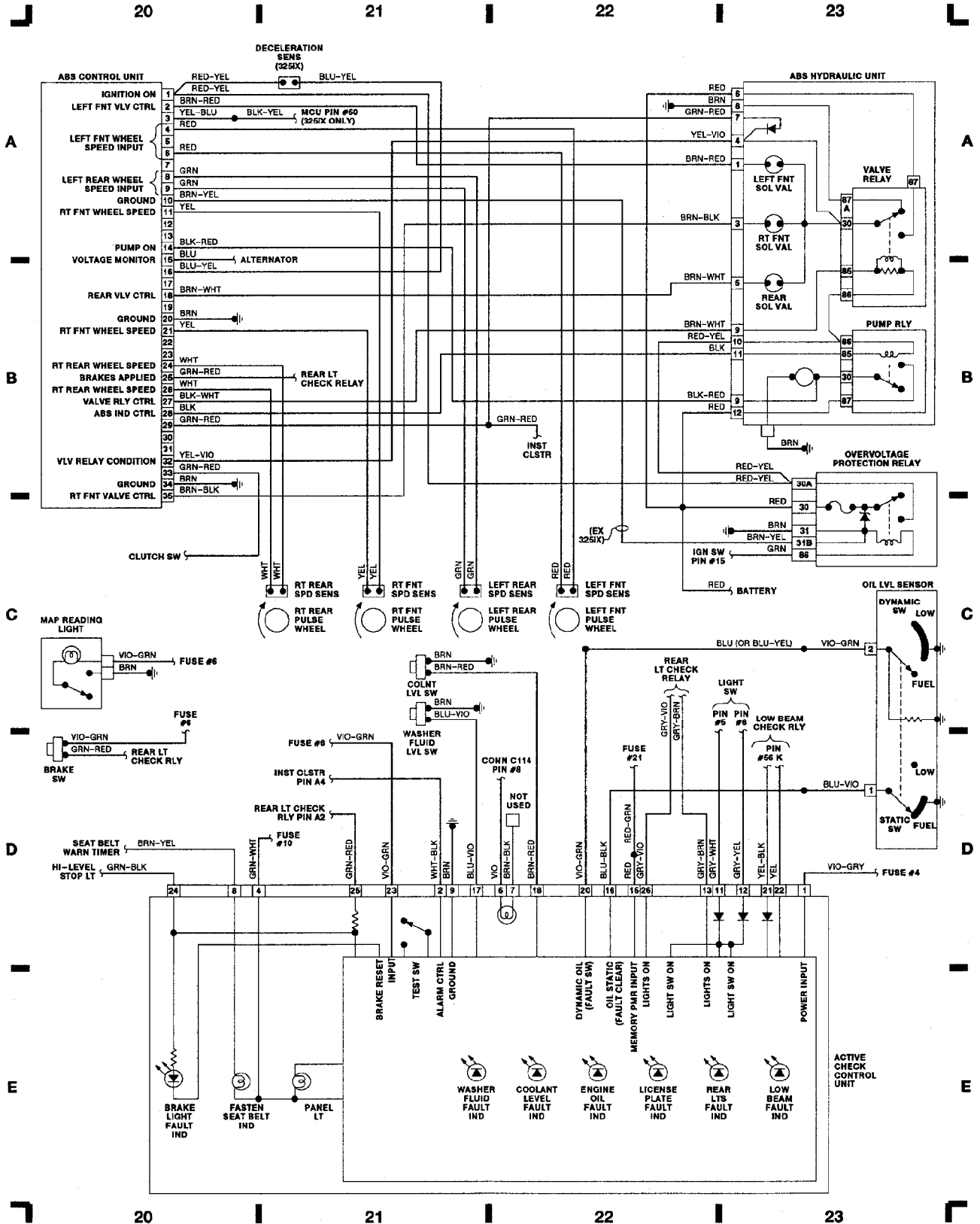

WIRING DIAGRAMS

Fig. 7: Underdash & Instrument Panel (Cont.)

1988 BMW 325i

For DIAKOM-AUTO <http://www.diakom.ru> Taganrog support@diakom.ru (8634)315187

Copyright © 1998 Mitchell Repair Information Company, LLC

Friday, November 03, 2000 05:25PM

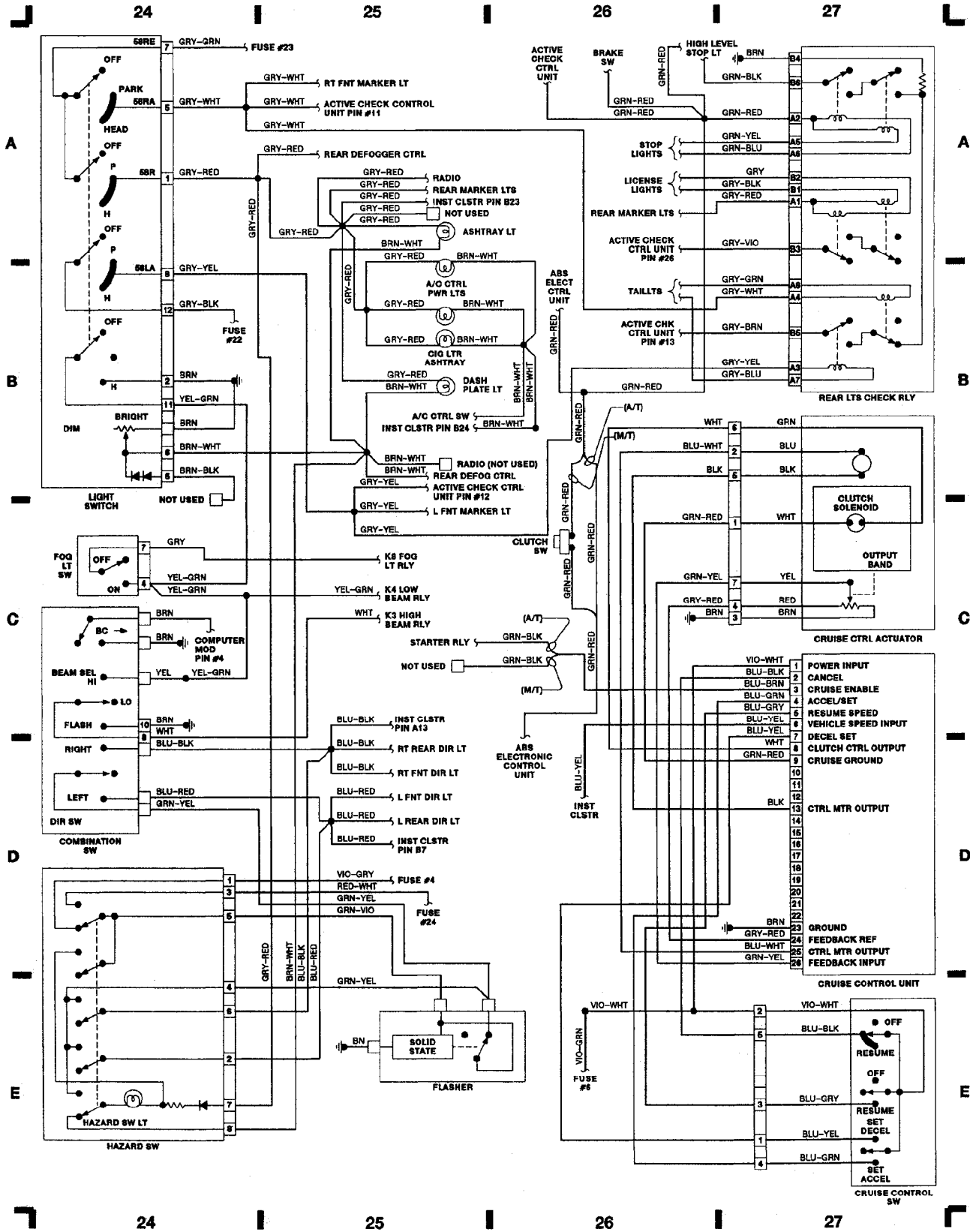

WIRING DIAGRAMS

Fig. 8: Instrument Panel (Cont.)

1988 BMW 325i

For DIAKOM-AUTO <http://www.diakom.ru> Taganrog support@diakom.ru (8634)315187
 Copyright © 1998 Mitchell Repair Information Company, LLC
 Friday, November 03, 2000 04:45PM

